



POLICY AND PROCEDURE FOR CROSS-CONNECTION CONTROL AND BACKFLOW PREVENTION

FOREWORD

In accordance with the Federal Safe Drinking Water Act, and requirements of the Ohio Environmental Protection Agency, the Ohio State Plumbing Code; the Geauga Public Health; and the Geauga County Department of Water Resources Policy and Procedure for Cross—Connection Control and Backflow Prevention; the Geauga County Department of Water Resources has established a policy and procedure for the protection of the public potable water supply.

The Policy and Procedures as outlined herein, along with other applicable codes, rules, and regulations, are designed to provide reasonable protection for the Geauga County Department of Water Resource's public potable water supply against Contamination and/or Pollution resulting from backflow and/or backsiphonage through uncontrolled plumbing connections and/or cross-connections.

Steven Oluic, PhD, Director
Gauga County Department of Water Resources

INDEX

SECTION	PAGE
I. INTENT, PURPOSE, AND CONTROL	1
II. RESPONSIBILITIES	2
III. IMPLEMENTATION AND ENFORCEMENT	3
IV. INSPECTION OF FACILITIES	3 -4
V. WATER FROM OTHER SOURCES AND FIRE HYDRANTS	4 - 5
VI. SELECTION OF DEVICES	5
VII. APPROVAL OF DEVICES	6
VIII. LOCATION AND INSTALLATION OF DEVICES	6 -7
IX. FIRE PROTECTION SYSTEMS	8 - 10
X. TESTS, MAINTENANCE, AND REPAIRS	10 - 11
XI. REMOVAL OF A BACKFLOW PREVENTION DEVICE	12
XII. ADDITIONAL INFORMATION	12
APPENDIX: TERMINOLOGY	13 - 16
XIII. OPEA RULES 3745-95 BACKFLOW	17—26
XIV. BACKFLOW PREVENTION DEVICE	27—32
BACKFLOW PREVENTION CHART	33
DEVICE SELECTION CHART & LIST	34 - 35
REFERENCES	36

**POLICY AND
PROCEDURE FOR
CROSS-CONNECTION CONTROL
AND
BACKFLOW REVENTION**

SECTION I. INTENT, PURPOSE, AND CONTROL

1. INTENT:

To recognize that all Consumer's water systems have connections to various apparatus, vessels, etc., that could have impurities and contaminates in varying degrees and, if not properly controlled and contained, could contaminate or pollute the user's and/or the Public potable water supply system. It is also the intent to apply the principal that the type of protection required shall be determined by whether the impurities are hazardous contaminants or nonhazardous pollutants.

2. PURPOSE:

(a) To protect the Geauga County Department of Water Resources public potable water system against actual or potential backflow and/or backsiphonage by containment, within a Consumer's premises, any pollution or contaminant that has entered, or may enter, into the Consumer's potable water system through an undiscovered or uncontrolled Cross- Connection on said premises.

(b) To eliminate uncontrolled Cross-Connections to non-potable systems as well as uncontrolled interconnections to any potable water system that is not part of the Geauga County Department of Water Resources water system, by installing an appropriate Backflow-Prevention Device(s) to isolate such system(s) from that of the Geauga County Department of Water Resources' potable water system.

3. CONTROL:

Requires cooperation between the Geauga County Department of Water Resources; Water Department, Plumbing Inspection Department, and the Consumer in the execution of and the adherence of the duties and responsibilities of each as set forth by this Policy, and these Procedures, in conjunction with other applicable codes, rules and regulations.

SECTION II. RESPONSIBILITIES:

1. THE GEauga COUNTY DEPARTMENT OF WATER RESOURCES (PURVEYOR):

The Superintendent of the Geauga County Department of Water Resources, as authorized through Water Ordinances adopted by the Geauga County Board of Commissioners, is primarily responsible for preventing the contamination and pollution of the Public potable water system by instituting a program of "Backflow Prevention". Such responsibility begins at the point of origin of the Public potable water supply and includes all of the distribution system, and terminates at the service connection for the Consumer's water system. The required consumer-supplied backflow-prevention device at the service-connection shall provide maximum (Reduced Pressure Zone assembly-RPZ) or minimum (Double Check Valve Assembly-DCV) protection as concluded by the Superintendent or his authorized representative. In addition, the Superintendent shall exercise reasonable vigilance to ensure that the consumer adheres to this Policy and these Procedures as stated and outlined herein.

2. THE INSPECTION/VERIFICATION DEPARTMENT (INSPECTOR):

If you are required by Geauga County Department of Water Resources to have a backflow preventer for your water service line, a Backflow Prevention Device Test and Maintenance Report must be completed by a certified backflow contractor with the City of Cleveland. Contact the City of Cleveland if you have any questions about the certified testers. Geauga County Department of Water Resources is primarily responsible for enforcing the plumbing code to prevent contamination and pollution within the consumer's water system through a program of "Cross-Connection Control" requiring that all plumbing outlets terminate through an approved air gap or be controlled by an approved mechanical backflow-prevention device. Such responsibility begins at the service-connection to the premises and extends to the extremities of the Consumer's potable water system.

3. THE CONSUMER (CUSTOMER):

The Consumer has the dual responsibility for protecting the potable water in their own system from degradation due to conditions originating on their premises, by complying with the plumbing code, and for protecting the quality of water in the Geauga County Department of Water Resources water supply against any potential or actual health hazard(s) generated on or from their premises through uncontrolled cross-connections, by backflow prevention at the service connection. Therefore, after Authority has been determined the type of backflow protection that is required at a Consumer's service connection, the Consumer is responsible for the costs of procurement, installation, and maintenance of said device.

SECTION III. IMPLEMENTATION AND ENFORCEMENT:

1. This policy and these Procedures shall be implemented immediately for Backflow-Prevention, in conjunction with existing Ohio State Plumbing Code requirements on Backflow prevention by Cross-Connection Control for all new domestic water, fire protection and irrigation system installations.
2. Implementation of this Policy and these Procedures shall also commence immediately on existing installations. Priority schedules shall be established, and evaluations made by the Geauga County Department of Water Resources for the Consumer's retrofit requirement at the service connection, beginning with those Consumers whose premises represent the greatest potential threat to the public potable water system. The Geauga County Department of Water Resources; however, shall not be responsible for abatement of cross-connections which may exist within a Consumer's premises. As a minimum, the evaluation shall consider: the existence of cross-connections; the nature of the materials handled on the property; the probability of a backflow occurring; the degree of piping system complexity; and the potential for system modification.
3. Enforcement of this Policy and these Procedures shall be administered by the Geauga County Department of Water Resources, utilizing its staff in cooperation with those of the Geauga County Health, and local Fire Departments as authorized by Board of County Commissioner of Geauga County.

SECTION IV. INSPECTION OF FACILITIES:

1. If, in the judgment of the Supervisor of Water Section, the integrity of the public water system is or can be endangered by backflow from an actual or a potential cross-connection within the plumbing system of a water consumer, the Supervisor may order the installation of an approved backflow prevention method or device consisting of either an ASSE ANSI, A112.12 Air Gap, ASSE 1015 Double Check Valve Assembly, ASSE 1020 Pressure Vacuum Breaker, ASSE 1013 Reduced Pressure Principle Backflow Preventer, ASME 1048 Double Check Detector Check Assembly, ASSE 1047 Reduced Pressure Principle Detector Check Assembly.
2. The water consumer shall install the designated device or method at their own expense, and failure, refusal or inability to install such device or method immediately shall constitute a ground for discontinuing water service to the premise until such device or method has been installed and approved by the Supervisor.
3. The Consumer, upon request, shall furnish to the Geauga County Department of Water Resources, any pertinent information regarding the Consumer's water system on such premises where backflow and/or backsiphonage are deemed possible through uncontrolled plumbing connections and/or cross-connections,
4. Nothing herein shall relieve the Consumer of the responsibility for conducting or causing to be conducted periodic surveys of water-use practices on their premises to determine whether there are actual or potential uncontrolled cross-connections within the Consumer's water system through which contaminants could flow back into their own or the Geauga County Department of Water Resources public potable water supply. If the premises is classified, restricted or high security with no admittance, maximum (rpz) protection at the service-connection is required.

5. Facilities considered to pose an actual or potential contamination and/or pollution threat to the public potable water supply will be subject to inspection by an authorized representative(s) of the Geauga County Department of Water Resources and, when deemed necessary, in accompaniment with a representative(s) from the Geauga County Health and/or local Fire Departments. Inspections will focus on plumbing outlets and potential contaminating or polluting substances within a facility. Inspections will be scheduled at a time mutually agreeable with the Consumer's representative and the Geauga County Department of Water Resources representative(s). Using information gathered, the Geauga County Department of Water Resources will determine the degree of potential backflow hazard and specify the type of backflow protection required at the Consumer's service-connection.
6. If, upon inspection, a facility is found not to be in full compliance with these policies and procedures, maximum protection will be required. If the owner brings the facility up to full code compliance within a ninety (90) day period, minimum protection will be allowed at the service-connection provided potential hazards within the premises are low.
7. After reasonable notice to the Consumer, of a violation of this Policy and/or these Procedures existing on the premises, water service shall be discontinued, and any other such precautionary measures taken that are deemed necessary to protect the quality of water in the Geauga County Department of Water Resources potable water supply. Water service shall not be restored until the danger has been eliminated in compliance with the provisions of this Procedure.
8. While in the course of a routine inspection or special investigation, the Inspector(s) discovers a condition of imminent or actual high hazard system contamination, the department's representative shall be authorized to IMMEDIATELY DISCONTINUE service to the facility. Service will not be restored until the hazardous condition has been corrected and reinspected.
9. In the event of accidental contamination or pollution of the Public potable water supply, the Consumer, if they are so aware, shall IMMEDIATELY NOTIFY the Geauga County Department of Water Resources so that appropriate measures may be taken to contain and isolate the contaminant and/or pollutant.

NOTE: Cost and liabilities are the Consumer's responsibility and known failure to report is a criminal offense under County, State and Federal Law.

SECTION V. WATER FROM OTHER SOURCES AND FIRE HYDRANTS:

1. When any premises is served by the Geauga County Department of Water Resources water system, and the owner of said premises continues to have a well or any other source of water, it shall be in violation of this Policy and/or Procedures for the plumbing on said premises to be installed or so interconnected that water in the Geauga County Department of Water Resources water supply and the private water supply can, in any way, become intermingled.
2. Upon discovery of an uncontrolled interconnection on any premises being furnished water through the County water system, as in Item (1) above, the owner of said premises shall be notified that the interconnection must be removed and/or controlled by an approved backflow-prevention device within thirty (30) days, and that failure to remove or correct the interconnection will result in removal of the meter. If the correction is not made within the thirty (30) day period, the meter will be removed and will not be reinstalled until the maximum-type backflow prevention is installed at the service connection, and the owner has paid for all associated costs.

3. Booster pumps installed on the service line to or within any premises, must be approved and permitted by the Geauga County Department of Water Resources, and such permitted pumps shall be equipped with a low- pressure cut-off device designed to shut off the booster pump when the pressure on the service line on the suction side of the pump drops to 10 PSI for 30 seconds. It shall be the duty of the water consumer to maintain the low-pressure cut-off device in proper working order at all times and to certify to the Geauga County Department of Water Resources, at least once a year that the device is operable.

NOTE: Consumer shall assume all liabilities.

SECTION VI. SELECTION OF DEVICES:

1. Vacuum breakers and backflow preventers shall be selected based on the impurities involved and the type of cross-connection. The impurities shall be classified as contaminants (hazardous) and/or pollutants (nonhazardous); and the cross-connection by whether it is a pressure or non-pressure as follows: (See Appendix: Terminology; page 13)
 - (a) CROSS-CONNECTION, NONPRESSURE TYPE: This type of connection, when not protected by a minimum air gap, shall be protected by an appropriate vacuum breaker or an approved backflow preventer (BFP).
 - (b) CROSS-CONNECTION, PRESSURE TYPE: This type of connection shall be protected by an approved BFP only.

CAUTION: A pressure vacuum breaker shall not be used alone on a pressure-type cross-connection.

NOTE: Because an irrigation system serves an environment that is open to atmosphere, it would not be classified as a pressure-type cross-connection. However, due to the special nature of the installation, minimum protection against backflow shall include a pressure vacuum breaker or a double check valve backflow preventer. If chemicals are injected into the system, minimum protection shall include a reduced pressure zone backflow preventer.

2. Vacuum breakers shall be corrosion resistant. Other backflow-prevention devices, including accessories, components, and fittings in sizes 2 inches and smaller shall be bronze with threaded connections. Sizes 2-1/2 inches and larger shall be bronze, or fused epoxy-coated iron inside and out, or ductile iron, with flanged connections.
3. Each device shall have a brass identification tag, securely attached with corrosion-resistant mechanical fasteners, and include the manufacturer's name, serial number, and maximum working pressure and temperature.
4. Each device must have the appropriately located test cocks.
5. The Geauga County Department of Water Resources shall make the determination of which type of device will be installed for containment.

SECTION VII. APPROVAL OF DEVICES:

All backflow-prevention devices shall be approved in accordance with the applicable standard of the American Society of Sanitary Engineering, the American National Standards Institute, the American Water Works Association, the University of Southern California Foundation for Cross-Connection Control and Hydraulic Research, and the State of OhioEPA.

EXCEPTION: If no standard yet exists for a particular device, or if the device is a derivative of one covered by a national standard, the Geauga County Department of Water Resources shall determine whether the device will be allowed.

SECTION VIII. LOCATION AND INSTALLATION OF DEVICES:

1. Location of all backflow-prevention devices shall be in an area that provides a safe working environment for testing and maintenance. This area shall be readily accessible and free from dirt, extreme cold, heat, and/or electrical hazards.
2. All backflow prevention devices shall be mounted in a horizontal position, unless specifically designed and approved to be mounted in any other position.
3. Installation of all backflow-prevention devices shall be in accordance with the Ohio Administrative Code, the following Procedures and other applicable codes and regulations. Installations for containment shall be by a duly licensed plumbing, mechanical and/or utility contractor; and as approved by the Geauga County Department of Water Resources.
 - (a) When a double check valve backflow-preventer is used in the containment concept, it shall be installed at or as close to the service-connection as practical. When installed in a vault, the construction shall be of watertight design, that will not flood, with a sump if subjected to ground water, and provided with an access ladder with sufficient light to permit maintenance, inspecting and testing.
 - (b) When a reduced pressure zone backflow preventer is installed at the service-connection it shall be above ground in a structure that is protected from freezing

NOTE When a backflow preventer is installed on a service pipe inside a structure on any premises for the purpose of containing said premises, it shall be unlawful to tap into such service pipe between the BFP and the service-connection. Any branch connection(s) on an existing service tap shall be permanently disconnected or equipped with a backflow preventer(s) commensurate with the degree(s) of hazard.

4. Facilities that must have a continuous uninterrupted water supply shall install backflow-prevention devices in parallel for testing and maintenance purposes. In no case shall a bypass arrangement be installed unless it also is equipped with an approved backflow-prevention device.
5. Vacuum breakers and backflow preventers equipped with atmospheric vents, or with relief openings, shall be so installed and so located as to prevent any vent or any relief opening from being submerged. They shall be installed in the position as recommended by the Manufacturer, and prescribed in the following:
 - (a) VACUUM BREAKER, PRESSURE TYPE (PVB): This device shall be installed at least 12 inches above the highest outlet or the overflow level on the non-potable system. It may be installed upstream of the last shut-off valve.

- (b) VACUUM BREAKER, HOSE TYPE (HVB): This device shall be installed directly on the hose threads, if not an integral part of the valve. It may not be subjected to continuous pressure, static or flowing. Nor shall it be attached to a freeze-less type hydrant unless it is a model specifically designated for this service.

CAUTION Freeze-less hydrants require manual winterization except those models with integral vacuum breakers and automatic drainage features.

- (c) BACKFLOW PREVENTER DOUBLE CHECK VALVE (DCV): This device shall not be buried in earth but may be installed below ground as in Paragraph (3a) provided ball valve test cocks fitted with brass plugs are used. Assembly bolts on bronze DCV's installed in pits shall be resistant to electrolysis. A full-port ball valve in sizes through 2 inch, and a ball or resilient-seated gate valve in sizes above 2 inch, shall be near the inlet and outlet sides of the device. The device shall be provided with three ball valve test cocks and a fourth test cock shall be provided on the upstream side of the inlet shut-off valve. When below ground, a union or flange shall be near the inlet and outlet sides. No intervening connection(s) shall be between the shut-off valves and the backflow preventer. Except where a meter or other device with bronze strainer, integral or attached, is immediately upstream of the backflow preventer, a bronze strainer shall be provided between the inlet shut-off valve and the device on sizes through 2 inch. When used on sizes larger than 2 inch, the strainer shall be of the same material as device.
- (d) BACKFLOW PREVENTER REDUCED PRESSURE ZONE (RPZ): This device shall not be installed below ground. Where relief valve discharge could cause water damage, it shall be piped via an air gap, or a funnel, at the vent/relief port to a floor drain or other approved location. Positive shut-off valves, test cocks, and strainers are to be provided as in Paragraph (c) above. No intervening branch connection(s) shall be between the shut-offs and the backflow preventer. (Figs. 1-4, Appendix)

NOTE: When a reduced pressure zone device is installed in a line subject to periodic no-flow conditions, and supply pressure subject to fluctuations, an auxiliary directional check with soft disc, capable of functioning in any position the BFP may be installed in, shall be provided between the inlet shut-off valve and the BFP head to lock the supply pressure in, and prevent unnecessary discharge through the vent/relief port. Make-up lines to chilled water systems and hydronic heating systems are examples of installations where a drop in supply pressure may occur during no-flow conditions. When a water pressure reducing valve is required in the same line with the RPZ device, it is usually possible to locate the reducing valve upstream of the device and take advantage of the check valve effect of the reducing valve. In such case, the auxiliary directional check would not be required.

***** SPECIAL CAUTION *****

THERMAL EXPANSION - When water is heated and stored in a distribution system, or a branch of the system, that has been closed by the installation of a backflow-prevention device, or any other checking device; an auxiliary relief valve, or expansion chamber, shall be installed to limit thermal expansion of the water being heated to not more than 80 psi static (no-flow) pressure at any fixture on the system.

SECTION IX. FIRE PROTECTION SYSTEMS:

1. For the purpose of BACKFLOW-PREVENTION by CONTAINMENT if the service-connection to a premises; from the Geauga County Department of Water Resources potable water supply, is intended to be used for fire protection service, it shall be classified and/or defined as follows:

- (a) DEDICATED service-connection - one that is designated to supply potable water for fire protection service ONLY.
- (b) COMBINATION service-connection - one that is designated to supply potable water for BOTH domestic use and fire protection service.

2. To further associate the sources of water that may utilized for fire protection and classes of fire protection systems, the following AWWA Classes shall also apply for Backflow-Prevention by Containment:

Class 1 - Directly supplied from Public water mains only: no pumps, tanks, or reservoirs; no physical connection from other water supplies; no antifreeze or additives of any kind; all sprinkler drains discharging to atmosphere, dry wells, or other safe outlets.

Class 2 - Directly supplied from public water mains, same as Class 1, except that authorization has been obtained for a booster pump to be installed in the supply line. **NOTE:** Must have special approval and be permitted by the Geauga County Department of Water Resources.

Class 3 - Directly supplied from public water mains, same as Class 1, plus one or more of the following: Elevated storage tanks; fire pumps taking suction from above ground covered reservoirs or tanks. All storage facilities shall be filled from the potable water supply and maintained in a potable condition.

Class 4 - Directly supplied from public water mains, similar to classes 1 and 2, and with an auxiliary water supply on or available to the premises; or an auxiliary water supply located within approximately 1,700 feet of the pumper connection.

Class 5 - Directly supplied from Public water mains, and interconnected with auxiliary supplies, such as: pumps taking suction from reservoirs exposed to contamination, or rivers and ponds; driven wells; mills or other industrial water systems; or where antifreeze or additives are used.

Class 6 - Directly supplied from Public water mains only, with or without gravity storage or pump suction tanks, and/or interconnections with industrial systems.

3. The following terminology and definitions for types of fire protection systems shall also be applicable;

- (a) Sprinkler System - includes express riser pipe that conveys water to the laterals that supply sprinkler heads.
 - i. Limited Area Sprinkler System - includes express riser pipe that conveys water to the laterals that supply sprinkler heads. Limited to a small area within the premises, and to 25 sprinkler heads. This may be connected directly to the water distribution system within the premises.
- (b) Standpipe System - includes bulk riser pipes equipped with hose connections, usually at each floor and roof, for exclusive use by the fire department; plus laterals on each floor of certain facilities that supply water to hose cabinets for use by the occupants to control incipient fires until the fire department arrives.

- (c) Combined Systems includes bulk and express riser pipes that supply both sprinkler and standpipe systems.
4. Fire systems shall be further classified and defined as:
- (a) **NONHAZARDOUS** - containing impurities Class 3 and lower. Also see, Terminology for Pollutants - Appendix.
 - (b) **HAZARDOUS** - containing impurities Class 4 and higher. Also see, Terminology for Contaminants - Appendix.
5. Fire protection systems as defined by the State Fire Code shall be contained from the Geauga County Department of Water Resources potable water supply by backflow-prevention devices as indicated and that have approvals as required under Section VII of this procedure and classified or listed by the Underwriters Laboratories and Factory Mutual Insurance, as follows:

Class 2 and 3 Sprinkler Systems, and Nonhazardous Standpipe or Combined Systems: shall be contained by the installation of a DOUBLE CHECK DETECTOR CHECK backflow preventer.

Class 4, 5 and 6 Sprinkler Systems, and Hazardous Standpipe or Combined Systems: shall be contained by the installation of a REDUCED PRESSURE ZONE DETECTOR CHECK backflow preventer.

Class Systems with Combination Hazards: shall be contained from the public water mains by procedures applicable to the component that requires the higher degree of protection.

6. The purpose of certain checking devices used, or likely to be used, with fire protection systems is outlined below to call attention to those that are approved for use as backflow- prevention devices and those that are not.
- (a) DIRECTIONAL CHECK - to provide direction flow only. Not an approved backflow- prevention device.
 - (b) ALARM CHECK - to signal an alarm; to summon the fire department, etc., when a sprinkler head flows water; and on wet-pipe systems, to provide directional flow. Not an approved backflow- prevention device.
 - (c) SINGLE DETECTOR CHECK - to detect unauthorized use of water for other than fire service; to detect leaks in fire protection systems; and, with by-pass check, to provide directional flow. Not an approved backflow-preventer.
 - (d) DOUBLE CHECK VALVE (DCV) to prevent backflow of polluted water into a potable water system; and to provide directional flow. Approved for use with full service Master or FM meters on a Combination service connection only.
 - (e) DOUBLE DETECTOR CHECK (DDC) - to prevent backflow of polluted water from a fire protection system into a potable water supply; to detect unauthorized use of water; to detect leaks in the fire protection system; and, to provide directional flow. Approved for use on a Dedicated service connection.
 - (f) REDUCED PRESSURE ZONE CHECK (RPZ) - to prevent backflow of contaminated water into a potable water system; and to provide directional flow. Approved for use on a Combination service as in Item (d).

- (g) REDUCED PRESSURE DETECTOR CHECK (RPDC) - to prevent backflow of contaminated water from a fire protection system into a potable water system; to detect unauthorized use of water; to detect leaks in the fire protection system; and, to provide directional flow. Approved for use on a Dedicated service as in Item (e).
- 7. Single detector checks that are used on nonhazardous fire protection systems Class 1, 2, or 3 may not be considered as a component part of a DDC backflow preventer. Specifically, the addition of a second single check to one of these devices may not be substituted for a Double Detector Check (DDC) assembly that is approved for backflow- prevention.
- 8. It is intended that the approved Double Detector Check (DDC) backflow preventer be in lieu of; not in addition to the two checking devices already required in the supply to Class 1 and 2 or, the double check valve BFP already required on Class 3 nonhazardous systems or, that the approved Reduced Pressure Detector Check (RPDC) be in addition to the RPZ already required on hazardous systems. The only additional checking device intended in the 3/4 inch copper detector check line, in conjunction with the bronze detector meter, is a 3/4 inch Double Check Valve (DCV) or Reduced Pressure Zone (RPZ).
- 9. The two shut-off valves required for periodic testing of the backflow prevention device shall be OS and Y, FDA approved fused epoxy coated inside and out, with resilient seats and the inlet valve shall include an approved test cock on the upstream side. All components shall be listed for fire protection service by Underwriters Laboratories and Factory Mutual.

EXPECTION:

Where limited area systems are installed as a part of the water distribution system within a premises, utilizing the same materials as the water distribution system and are not provided with a fire department connection, isolation of the water supply system shall not be required.

SECTION X. TESTS, MAINTENANCE AND REPAIRS:

- 1. All backflow-prevention devices, both existing and new, and all parts thereof, shall be maintained in a safe and reliable operating condition.
- 2. The consumer shall be responsible for the cost of testing, maintenance, and repair of all backflow-prevention devices downstream of the service-connection within the premises and on their own private systems.
- 3. The consumer is responsible for backsiphoned material or contamination and/or pollution through backflow and, if contamination or pollution of the Geauga County Department of Water Resources public potable water system occurs through an illegal cross-connection and/or an improperly installed, maintained or repaired device, or a device that has been bypassed, he shall be liable for all associated costs of clean-up required for the public potable water system.
- 4. Tests, maintenance, and repairs on BFP devices are to be made in accordance with the following schedule or more frequently where inspections indicate a need or are specified in the manufacturer's instructions:
 - (a) FIXED AIR GAP SEPARATIONS - shall be inspected at the time of installation and at least annually thereafter.

- (b) PRESSURE VACUUM BREAKERS - shall be inspected and tested at the time of installation and at least annually thereafter.
 - (c) DOUBLE CHECK VALVE BACKFLOW PREVENTERS - shall be inspected and tested at the time of installation and at least annually thereafter.
 - (d) REDUCED PRESSURE ZONE BACKFLOW PREVENTERS - shall be inspected at the time of installation and at least annually thereafter.
 - (e) SYNTHETIC COMPONENTS WITHIN A DEVICE - shall be replaced as required.
5. Test procedures for all backflow-prevention devices shall be as outlined in the: UNIVERSITY OF SOUTHERN CALIFORNIA, FOUNDATION FOR CROSS-CONNECTION CONTROL AND HYDRAULIC RESEARCH; MANUAL OF CROSS-CONNECTION CONTROL.
 6. Testing must be performed by an individual(s) who is certified and/or trained to understand the design and intended operation of the device(s) being tested and has proven their competency to the Geauga County Department of Water Resources. Each individual must hold a current Ohio Department of Commerce certificate or an Operators Training Committee of Ohio certificate.
 7. A test and maintenance record for each RPZ, DCV, and PVB device used in the containment concept shall be maintained by the Consumer. Following each test or repair, a report must be sent to the Geauga County Department of Water Resources, and must include the following:
 - (a) Date of installation and location of device:
 - (b) Manufacturer's name, model and serial number:
 - (c) Date of each test or visual inspection:
 - (d) Name of authorized person performing test:
 - (e) Test results
 - (f) Description of repairs or service required:
 - (g) Date of repairs completed:
 - (h) Name and signature of device owner or authorized official.
 8. All backflow-prevention devices and test data shall be subject to periodic inspection by a representative of the Geauga County Department of Water Resources. If a device is found to be inoperative or malfunctioning, the Consumer will be given a reasonable time to complete corrections required by the Inspector or Representative, With the exception of cases involving actual or imminent system contamination, the time allotted for correction will be determined by potential hazard posed to the Public Potable Water Supply.
 9. If all corrective measures have not been taken in the allotted time, termination of water service will be recommended. If the Supervisor concurs, the Consumer will receive a certified letter of intent to terminate service. Termination procedures will be initiated (10) days after receipt. If the Consumer completes the corrections prior to the deadline, termination procedures will be stopped.

SECTION XI: REMOVAL OF A BACKFLOW PREVENTION DEVICE

All backflow prevention devices were installed to protect the public potable water system against actual or potential backflow and/or backsiphonage by containment, within a Consumer’s premises, any pollution or contaminant that has entered, or may enter into the Consumer’s potable water system through any undiscovered or uncontrolled Cross-Connection on said premises.

While it is not recommended that a backflow prevention device be removed, there are circumstances when the removal of the device will be considered.

1. The removal of a boiler for a heating system.

When a hot water or a steam boiler system is removed from a premises and a new type of heating plant is installed, the backflow prevention device may be removed when the following conditions have been met:

- (a) The boiler must be completely removed from the premises
- (b) The water lines to the boiler must be cut and capped
- (c) A Geauga Public Health plumbing permit must be obtained for the work
- (d) The Health Department must be informed for an inspection to ensure that the previous conditions have been met.

Upon the completion of the inspection, and all of the above conditions have been met, the backflow device will be deactivated from the records and will no longer be required to be tested.

2. Lawn irrigation system.

When a lawn irrigation system is no longer permanently being used, it may be disconnected from the system and the backflow prevention device can be removed, providing the following conditions have been met:

- (a) A Geauga Public Health plumbing permit must be obtained for the work
- (b) The line supplying the system must be cut and capped at the branch off of the main incoming line.
- (c) If the outside underground system is not removed, the supply line must be cut a minimum of 10 (ten) feet away from the foundation of the house.
- (d) Lawn irrigation control panel must be removed.
- (e) The Health Department must be informed for an inspection to ensure that the previous conditions have been met.

Upon the completion of the inspection, and all of the above conditions have been met, the backflow device will be deactivated from the records and will no longer be required to be tested.

SECTION XII: ADDITIONAL INFORMATION:

Any questions regarding this policy and/or these procedures may be directed to the:

GEAUGA COUNTY DEPARTMENT OF WATER RESOURCES
470 CENTER STREET, BUILDING #3
CHARDON, OHIO 44024
PHONE: (440) 279-1970

TERMINOLOGY FOR BACKFLOW-PREVENTION PROGRAM

AUTHORITY the individual, official board, department or agency established and authorized by county and/or other political subdivision created by law to administer and enforce the provisions of the Plumbing Code, the Federal and State Safe Drinking Water Acts, and the Ordinances, Rules Regulations, and Policies of The Geauga County Department of Water Resources, in the State of Ohio.

AIR GAP SEPARATION - the unobstructed vertical distance through the free atmosphere between the lowest opening from any pipe or faucet supplying water to a tank, plumbing fixture or other device and the flood level rim of the receptacle.

APPROVED - means that a backflow-prevention device or method has been accepted by the supplier of water and the Director as suitable for proper use.

AUXILIARY WATER SYSTEM - any water system on or available to the premises other than the public water system and includes the water supplied by the system. These auxiliary waters may include water from another supplier's public water system; or water from a source such as wells, lakes, or streams; or process fluids; or used water. They may be polluted or contaminated or objectionable or constitute a water source or system over which the supplier of water does not have control.

BACKFLOW - the flow of water or other liquids, mixtures, or substances into the distribution pipes of a potable water supply from any source other than the intended source of the potable water supply.

BACKFLOW PREVENTER (BFP) - a device designed to prevent reverse flow in a water system. The term should normally be used when backpressure-type backflow is implied.

BACKFLOW PREVENTER, DOUBLE CHECK VALVE (DCV) - a backpressure-type backflow-prevention device designed for continuous or intermittent pressure, including backpressure, where pollutants are involved.

BACKFLOW PREVENTER, DOUBLE DETECTOR CHECK (DDC) - a backpressure-type backflow-prevention device designed to serve also as a detector check on fire protection systems where pollutants are involved. It includes a line-size approved double check valve backflow preventer with a metered bypass, into which has also been incorporated an approved double check valve backflow preventer.

BACKFLOW PREVENTER, REDUCED PRESSURE ZONE (RPZ) - a backpressure and backsiphonage-type backflow-prevention device designed to operate under continuous pressure, including backpressure, where contaminants are involved.

BACKFLOW PREVENTER, REDUCED PRESSURE DETECTOR CHECK (RPDC) -a backpressure and backsiphonage-type backflow-prevention device designed to serve also as a detector check on fire protection systems where contaminants are involved. It includes a line-size reduced pressure zone backflow preventer with a metered bypass, into which has also been incorporated an approved reduced pressure zone backflow preventer.

BACKFLOW-PREVENTION - a program, an ordinance, a code, a policy; designed to discover, to eliminate, to prevent; all unauthorized and uncontrolled backflow and cross-connections.

BACKFLOW-PREVENTION BY CROSS-CONNECTION CONTROL - the installation of a backflow-prevention device at each cross-connection on a premises to protect both the premises and the Public Water Supply System.

BACKFLOW-PREVENTION BY CONTAINMENT - the installation of a backflow- prevention device at the service connection to protect only the Public Water Supply System.

BACKFLOW PREVENTION DEVICE - any device, method, or type of construction intended to prevent backflow into a potable water system.

BACKPRESSURE - an increase in pressure in a Consumer's water system, or a branch of the system, above that of the service-connection. It is generally caused by pumps, thermal expansion, or reasons other than a reduction or loss of the incoming pressure. Backpressure is generally more evident in a closed water system.

BACKSIPHONAGE - a reverse flow in a water system caused by a negative pressure in the incoming pipe, when the point of use is at atmospheric pressure. Backsiphonage is generally more evident in an open water system.

BACKSIPHONAGE PREVENTER - a device designed to prevent reverse flow in a water system. The term should be used only where a negative supply pressure is implied.

BACKFLOW-PREVENTION DEVICE TECHNICIAN (CERTIFIED TESTER) - a person qualified to test and/or repair backflow-prevention and cross-connection control devices; and who has proven their competency to the Geauga County Department of Water Resources. Must hold a current Ohio Department of Commerce certificate or an Operators Training Committee of Ohio certificate

CLOSED WATER SYSTEM - one with a checking device installed in the service pipe. A check valve, backflow preventer, or pressure reducing valve would create a closed system.

CONSUMER - the owner or person in control of any premises supplied by or in any manner connected to a public water system.

CONSUMER'S WATER SYSTEM - all potable water piping, valves, fittings, and appurtenances on the premises, supplied by or in any manner connected to a public water system. A household plumbing system is considered to be a consumer's water system.

CONTAMINANT - any substance that, if introduced into the potable water system, could create a health hazard.

CONTAMINATION - an impairment of the quality of the water by sewage or process fluids or waste to a degree which could create an actual hazard to the public health through poisoning or through spread of disease by exposure.

CROSS-CONNECTION - a physical connection or arrangement between two otherwise separate piping systems; one of which contains potable water, the other a non-potable fluid, or water of unknown quality, where there could be backflow into the potable system unless it is protected by an appropriate backflow-prevention device.

CROSS-CONNECTION, NONPRESSURE TYPE - a low-inlet installation where a potable water pipe is connected or extended below the overflow rim of a receptacle, or an environment, that contains non-potable fluid, and is at atmospheric pressure.

CROSS-CONNECTION, PRESSURE TYPE - an installation where a potable water pipe is connected to a closed vessel, or a piping system that contains non-potable fluid, and is above atmospheric pressure.

DEGREE OF HAZARD - a term derived from an evaluation of the potential risk to health and the adverse effect upon the potable water system, which can range in severity from mildly toxic to lethal.

DIRECTOR - the director of environmental protection or his duly authorized representative.

DOUBLE CHECK VALVE ASSEMBLY - an assembly composed of two single, independently acting, check valves including tightly closing shutoff valves located at each end of the assembly and suitable connections for testing the water-tightness of each check valve.

HEALTH HAZARD - any condition, device or practice in a water system or its operation that creates, or may create, a danger to the health and well-being of users. The word "severe" as used to qualify "health hazard" means a hazard to the health of the user that could reasonably be expected to result in significant morbidity or death.

INSPECTOR - an individual qualified in a vocation and authorized to make inspections, interpret codes, regulations, and procedures.

INTERCHANGEABLE CONNECTIONS - an arrangement or device that will allow alternate but not simultaneous use of two sources of water. This device alone is not an approved backflow-prevention device.

LAWN IRRIGATION SYSTEM — any permanently installed in-ground piping that is used for the purpose of supplying water to a lawn, garden or any type of landscaping. This system can be supplied by a permanent connection to the plumbing system of a building, or a removable connection using a section of garden hose connected to a hose bib.

LIMITED AREA SPRINKLER SYSTEM a fire suppression system used to protect a small area within the premises, limited to 25 sprinkler heads.

NON-POTABLE WATER - water not safe for drinking. personal or culinary use.

OPEN WATER SYSTEM - one with no checking devices installed in the service pipe. Water from the Consumer's system is free to backflow into the main, for whatever reason.

PERSON - means the state, any political subdivision, public or private corporation, individual, partnership, or other legal entity.

POLLUTANT - any substance that, if introduced into the potable water system, would be objectionable but could not create a health hazard.

POLLUTION - the presence in the potable water system of any foreign substance that tends to degrade its quality so as to constitute a hazard or impair the usefulness or quality of the water to a degree which does not create an actual hazard to public health but which does adversely and unreasonably affect such waters for domestic use.

POLLUTION HAZARD - a condition through which an aesthetically objectionable or degrading material not dangerous to health may enter the public water system or a potable consumer's water system.

POTABLE WATER - water which is satisfactory for drinking, culinary, and domestic purposes and meets the requirements of the environment protection agency.

PROCESS FLUIDS - any fluid or solution which may be chemically, biological or otherwise contaminated or polluted in a form or concentration such as would constitute a health, pollution, or system hazard if introduced into the public or a potable consumer's water system. This includes, but is not limited to:

- (1) Polluted or contaminated waters;
- (2) Process waters;
- (3) Used waters originating from the public water system which may have deteriorated in sanitary quality;
- (4) Cooling waters;
- (5) Contaminated natural waters taken from wells, lakes, streams, or irrigation systems;

- (6) Chemicals in solution or suspension;
- (7) oils, gasses, acids, alkalis, and other liquid and gaseous fluids used in industrial or other processes, or for firefighting purposes.

PUBLIC WATER SYSTEM - has the meaning ascribed to such term in rule 3745-81-01 of the Administrative Code.

REDUCED PRESSURE PRINCIPLE BACKFLOW PREVENTION DEVICE - a device containing a minimum of two independently acting check valves together with an automatically operating pressure differential relief valve located between two check valves. During normal flow and at the cessation of normal flow, the pressure between these two checks shall be less than the supply pressure. In case of leakage of either check valve, the differential relief valve, by discharging to the atmosphere, shall operate to maintain the pressure between the check valves at less than the supply pressure. The unit must include tightly closing shutoff valves located at each end of the device, and each device shall be fitted with properly located test cocks.

REPRESENTATIVE - a person authorized to represent the Director of the Geauga County Department of Water Resources.

SERVICE-CONNECTION - the point of delivery of water to a premises; the normal location of the meter. It is the end of the water purveyor's jurisdiction and the beginning of the Plumbing Official's and Consumer's, and defined as follows:

DEDICATED - a single service connection that is designated for one use only; (i.e., domestic, fire protection, or irrigation.)

COMBINATION - a single service connection that is designated for more than one use; (i.e., domestic and fire protection.)

SEVERE HEALTH HAZARD - a hazard to the health of the water user that could be expected to result in significant morbidity or death.

SUPPLIER OF WATER - the owner or operator of a public water system.

SYSTEM HAZARD - a condition posing an actual or potential threat of damage to the physical properties of the public water system or a potable consumer's water system.

USED WATER any water supplied by a supplier of water from public water system to a consumer's water system after it has passed through the service connection and is no longer under the control of the supplier.

VACUUM BREAKER (VB) - a backsiphonage-prevention device that introduces air into the potable water system when the system pressure approaches zero. It is designed for use where the receptacle or environment being served is subject to atmospheric pressure only.

VACUUM BREAKER, ATMOSPHERIC TYPE (AVB) - a backsiphonage-prevention device designed for use under flow conditions only, not to exceed 12 consecutive hours, and where it will be subject to no static pressure, and no backpressure.

VACUUM BREAKER, PRESSURE TYPE (PVB) - a backsiphonage-prevention device designed to operate under continuous pressure; static or flowing, but on backpressure.

VACUUM BREAKER, HOSE TYPE (HVB) - a backsiphonage-prevention device designed for hose connections only, but not for continuous pressure, static or flowing.

VACUUM RELIEF VALVE - a device designed to limit the degree of vacuum in a vessel or pipe, but not for cross-connection control.

SECTION XIII.

CHAPTER 3745-95 BACKFLOW PREVENTION AND CROSS - CONNECTION CONTROL

3745-95-01 BACKFLOW PREVENTION AND CROSS - CONNECTION CONTROL DEFINITIONS.

As used in this chapter of the Administrative Code:

(A)

(1) "Air gap separation" means the unobstructed vertical distance through the free atmosphere between the lowest opening from any pipe or

faucet supplying water to a tank, plumbing fixture, or other device and the flood level rim of the receptacle.

(2) "Approved" means that a backflow prevention assembly, device, or method has been accepted by the supplier of water and the director as suitable for the proposed use.

(3) "Auxiliary water system" means any water system on or available to the premises other than the public water system. These auxiliary water systems shall include used water or water from a source other than the public water system, such as wells, cisterns or open reservoirs that are equipped with pumps or other prime movers, including gravity.

(B)

(1) "Backflow" means the flow of water or other liquids, mixtures, or substances into the distributing pipes of a potable water supply from any source other than the intended source of the potable water supply.

(2) "Backflow preventer" means any assembly, device, method or type of construction intended to prevent backflow into a potable water system. This definition applies wherever "backflow prevention device" is used in this chapter.

(3) "Booster pump" means any device which is intended to increase the in-line water pressure.

(C)

(1) "Consumer" means the owner or person in control of any premises supplied by or in any manner connected to a public water system.

(2) "Consumer's water system" means any water system, located on the consumer's premises, supplied by or in any manner connected to a public water system. A household plumbing system is considered to be a consumer's water system.

(3) "Containment principle backflow preventer" is a backflow preventer, installed in a consumer's water system, that is intended to contain the water within the premises in order to prevent any polluted or contaminated water from backflowing into the public water system. Typically, the containment principle backflow preventer is placed at the service connection unless placement is otherwise specified by rule herein.

(4) "Cross-connection" means any arrangement whereby backflow can occur.

(D)

(1) "Degree of hazard" is a term derived from an evaluation of the potential risk to health and welfare.

(2) "Director" means the director of environmental protection or the director's duly authorized representative.

(3) "Double check valve assembly" means an assembly composed of two single, independently acting, check valves including tightly closing shutoff valves located at each end of the assembly and suitable connections for testing the water tightness of each check valve.

(4) "Double check-detector check valve assembly" means a specially designed assembly composed of a line-size approved double check valve assembly with a specific bypass water meter and a meter-sized approved double check valve assembly. The meter shall register accurately for only very low rates of flow and shall show a registration for all rates of flow.

(E) [Reserved.]

(F) [Reserved.]

(G) [Reserved.]

(H)

(1) "Health hazard" means any condition, device, or practice in a water system or its operation that creates, or may create, a danger to the health of users.

(2) "Human consumption" means the ingestion or absorption of water or water vapor as the result of drinking, cooking, dishwashing, hand washing, bathing, showering or oral hygiene.

(I) "Interchangeable connection" means an arrangement or device that will allow alternate but not simultaneous use of two sources of water and includes an approved reduced pressure principle backflow prevention assembly or an approved reduced pressure principle-detector assembly on the public water system side of the connection.

(J) [Reserved.]

(K) [Reserved.]

(L) [Reserved.]

(M) [Reserved.]

(N) [Reserved.]

(O) [Reserved.]

(P)

(1) "Person" means the state, any political subdivision, public or private corporation, individual, partnership, or other legal entity.

(2) "Pollutional hazard" means a condition through which an aesthetically objectionable or degrading material, which is not dangerous to the public water system or health of users, may enter the public water system or portion of a consumer's water system.

(3) "Potable water" means water intended for human consumption.

(4) "Premises" means any building, structure, dwelling or area containing plumbing or piping supplied from a public water system.

(5) "Pressure vacuum breaker" means an assembly composed of an independently acting

spring loaded check valve located downstream of an independently acting spring loaded air inlet valve including, tightly closing shutoff valves located at each end of the assembly and suitable connections for testing the integrity of the air inlet and check valves.

(6) "Process fluids" means any fluid or solution which may be chemically, biologically or otherwise contaminated or polluted in a form or concentration such as would constitute a pollutional, system, health or severe health hazard if introduced into the public water system or portion of a consumer's water system. This includes, but is not limited to the following

(a) Polluted or contaminated waters.

(b) Process waters

(c) Used waters originating from a public water system which may have deteriorated in sanitary quality.

(d) Cooling waters.

(e) Contaminated natural waters taken from wells, lakes, streams or irrigation systems.

(f) Chemicals in solution or suspension.

(g) Oils, gases, acids, alkalis, and other liquid and gaseous fluids used in industrial or other processes, or for fire fighting purposes.

(7) "Public water system" has the same meaning as in rule [3745-81-01](#) of the Administrative Code.

(Q) [Reserved.]

(R)

(1) "Reduced pressure principle backflow prevention assembly" means an assembly containing a minimum of two independently acting check valves together with an automatically operated pressure differential relief valve located between the two check valves. During normal flow and at the cessation of normal flow, the pressure between these two checks shall be less than the supply pressure. In case of leakage of either check valve, the differential relief valve, by discharging to the atmosphere, shall operate to maintain the pressure between the check valves at less than the supply pressure. The unit must include tightly closing shutoff valves located at each end

of the assembly, and each assembly shall be fitted with properly located test cocks.

(2) "Reduced pressure principle-detector assembly" means a specially designed assembly composed of a line-size approved reduced pressure principle backflow prevention assembly with a specific bypass water meter and a meter sized approved reduced pressure principle backflow prevention assembly. The meter shall register accurately for only very low rates of flow and shall show a registration for all rates of flows.

(S)

(1) "Service connection," for the purposes of this chapter, means the terminal end of a service line from the public water system. If a meter is installed at the end of the service, then the service connection means the downstream end of the meter.

(2) "Severe health hazard" means a health hazard to users that could reasonably be expected to result in significant morbidity or death.

(3) "Supplier of water" means the owner or operator of a public water system.

(4) "System hazard" means a condition posing an actual or potential threat of damage to the physical properties of the public water system or a consumer's water system.

(T) [Reserved.]

(U) "Used water" means any water supplied by a supplier of water from a public water system to a consumer's water system after the water has passed through the service connection and is no longer under the control of the supplier.

(V) [Reserved.]

(W)

(1) "Water system" means a system for the provision of piped water or process fluids, and includes any collection, treatment, storage or distribution facilities used primarily in connection with such system.

(2) "Weep holes" means a series of small diameter holes located in the wall of the supply pipe for a yard hydrant that allow for drainage of

accumulated water from the delivery piping. These holes are usually part of a plunger and valve system that seals off the holes during water usage and opens the holes during shutdown. These openings are located below ground level and below the frost line in areas where the threat of freezing exists.

(X) [Reserved.]

(Y) "Yard hydrant" means a device that is located outside of a building, equipped with a valved mechanism that controls the delivery of potable water, and is not designed to supply a fire department pumper.

(Z) [Reserved.]

Effective: 10/26/2015

Five Year Review (FYR) Dates: 07/06/2015 and 10/26/2020

Promulgated Under: [119.03](#)

Statutory Authority: [6109.04](#)

Rule Amplifies: [6109.04](#), [6109.13](#)

Prior Effective Dates: 07/01/72, 11/26/80, 05/01/03, 10/01/06, 04/19/12

3745-95-02 BACKFLOW PREVENTION AND CROSS — CONNECTION CONTROL.

(A) No person shall install or maintain a water service connection to any premises where actual or potential cross-connections to a public water system or a consumer's water system may exist unless such actual or potential cross-connections are abated or controlled to the satisfaction of the supplier of water.

(B) No person shall install or maintain a connection between a public water system or consumer's water system and an auxiliary water system unless the auxiliary water system, the method of connection and the use of such system have been approved by the supplier of water and by the director as required by section [6109.13](#) of the Revised Code.

(C) A public water system shall develop and implement a backflow prevention and cross-connection control program consistent with this chapter.

Effective: 10/26/2015

Five Year Review (FYR) Dates: 07/06/2015 and 10/26/2020

Promulgated Under: [119.03](#)

Statutory Authority: [6109.04](#)

Rule Amplifies: [6109.04](#), [6109.13](#)

Prior Effective Dates: 07/01/72, 11/26/80, 05/01/03

3745-95-03 SURVEY AND INVESTIGATIONS.

(A) The supplier of water shall conduct or cause to be conducted an initial assessment and periodic surveys or investigations of water use practices within a consumer's premises to determine whether there are actual or potential cross-connections to the consumer's water system through which contaminants or pollutants could backflow into the public water system or determine where in the judgment of the supplier of water, a pollutional system, health or severe health hazard to the public water system exists.

To meet this requirement, the supplier of water shall conduct or cause to be conducted an on-site investigation of all premises at least every five years to identify changes in water use practices at the consumer's property so that new or increased hazards to the water supply are identified and mitigated.

(1) In lieu of conducting an on-site investigation of all premises every five years, the supplier of water can document, in writing, an alternate, on-going, methodology to identify changes in water use practices that may represent a new or increased hazard to the public water supply. An on-site investigation is required when a potential new or increased hazard is suspected to confirm the degree of risk and how it will be addressed. Information obtained through a water use survey questionnaire or in coordination with the local building, zoning, health, fire protection and other licensing agencies may be used as an indicator of when an on-site investigation should be conducted. Other triggers, such as a request to the supplier of water for a new or additional service line, or an additional or larger meter should warrant an on-site investigation.

(2) In lieu of conducting an on-site investigation of each residential premise, the supplier of water may institute an on-going educational campaign to inform consumers of common backflow hazards created during residential water use and provide a reporting mechanism for suspected cross-connections. An education campaign may use local media and advertising resources, but must also include information delivered, either electronically or hard copy, to each residential service connection at least annually.

(B) The supplier of water, or the supplier's authorized representative, shall have the right to enter premises served by the public water system at all reasonable times for the purpose of making surveys and investigations of water use practices within the premises.

(C) On request by the supplier of water, or the supplier's authorized representative, the consumer shall furnish the supplier, or the supplier's authorized representative, information on water use practices within the consumer's premises.

(D) Paragraph (A) of this rule does not relieve the consumer of the responsibility for conducting, or causing to be conducted, periodic surveys of water use practices on his premises to determine whether there are actual or potential cross-connections in the consumer's water system through which contaminants or pollutants could backflow into a public water system or a potable consumer's water system.

Effective: 10/26/2015

Five Year Review (FYR) Dates: 07/06/2015 and 10/26/2020

Promulgated Under: [119.03](#)

Statutory Authority: [6109.04](#)

Rule Amplifies: [6109.04](#), [6109.13](#)

Prior Effective Dates: 07/01/72, 11/26/80

3745-95-04 WHERE PROTECTION IS REQUIRED.

(A) An approved backflow preventer shall be installed on each service line to a consumer's water system serving premises, where in the judgment of the supplier of water or the director, a pollutional, system, health or severe health hazard to the public water system exists.

(B) An approved backflow preventer shall be installed on each service line to a consumer's water system serving premises where any of the following conditions exist:

(1) Premises having an auxiliary water system on the premises, unless such auxiliary system is accepted as an additional source by the supplier of water and the source is approved by the directory

(2) Premises on which any substance is handled in such a fashion as to create an actual or potential hazard to a public water system. This shall include premises having sources or systems containing process fluids

(3) Premises having internal cross-connections that, in the judgment of the supplier of water, are not correctable, or intricate plumbing arrangements which make it impracticable to determine whether or not cross-connections exist;

(4) Premises where, because of security requirements or other prohibitions or restrictions, it is impossible or impractical to make a complete cross-connection survey;

(5) Premises having a repeated history of cross-connections being established or re-established.

(6) Others specified by the director.

(C) The following requirements apply to premises that have an auxiliary water system on the real property that is owned or under control of the consumer and adjacent to the premises.

(1) A physical separation shall be maintained between the public water system or a consumer's water system and the auxiliary water system as required by paragraph (B) of rule [3745-95-02](#) of the Administrative Code.

(2) An approved backflow preventer shall be installed on each service connection serving the consumer's water system, unless the supplier of water does all of the following:

(a) Determines, on a case-by-case basis, that the installation of an approved backflow preventer on a service connection is not required in consideration of factors including, but not limited to, the past history of cross connections being established or re-established on the premises, the ease or difficulty of connecting the auxiliary water system with the public water system on the premises, the presence or absence of contaminants on the property or other risk factors;

(b) Requires the consumer to sign an agreement which specifies the penalties, including those set forth in rule [3745-95-08](#) of the Administrative Code, for creating a connection between the public water system and the auxiliary water system;

(c) Conducts or causes to be conducted an inspection at least every twelve months to certify that no connection or means of connection has been created between the public water system and the auxiliary water system;

(d) Maintains an inventory of each consumer's premises where an auxiliary water system is on or available to the premises, or on the real property adjacent to the premises.

(e) Develops and implements an education program to inform all consumers served by the public water system about the dangers of cross-connections and how to eliminate cross-connections.

(D) An approved backflow preventer shall be installed on each service line to a consumer's water system serving, but not necessarily limited to, the following types of facilities unless the director determines that no severe health, health, system or pollutional hazard to the public water system exists:

(1) Hospitals, mortuaries, clinics, nursing homes;

(2) Laboratories;

(3) Piers, docks, waterfront facilities;

(4) Sewage treatment plants, sewage pumping stations, or storm water pumping stations;

(5) Food or beverage processing plants;

(6) Chemical plants;

(7) Metal plating industries;

(8) Petroleum processing or storage plants;

(9) Radioactive material processing plants or nuclear reactors;

(10) Car washes

(11) Others specified by the director.

(E) An approved backflow preventer shall be installed at any point of connection that is approved in accordance with paragraph (B) of rule [3745-95-02](#) of the Administrative Code between a public water system or a consumer's water system and an auxiliary water system, unless such auxiliary system is accepted as an additional source by the supplier of water and the source is approved by the director.

R.C. [119.032](#) review dates: 01/07/2013 and 01/07/2018

Promulgated Under: [119.03](#)

Statutory Authority: [6109.04](#)

Rule Amplifies: [6109.01](#), [6109.03](#), [6109.04](#), [6109.13](#)

Prior Effective Dates: 7/1/72, 11/26/80

3745-95-05 TYPE OF PROTECTION REQUIRED.

(A) The type of protection required under paragraphs (A), (B), (C) and (D) of rule [3745-95-04](#) of the Administrative Code shall depend on the degree of hazard which exists as follows:

(1) An approved air gap separation shall be installed where a public water system may be contaminated with substances that could cause a severe health hazard.

(2) An approved air gap separation, an approved reduced pressure principle backflow prevention assembly or an approved reduced pressure detector check assembly shall be installed where a public water system may be contaminated with any substance that could cause a system or health hazard.

(3) An approved air gap separation, an approved reduced pressure principle backflow prevention assembly, an approved reduced pressure principle-detector check assembly, an approved double check valve assembly or an approved double check-detector check valve assembly shall be installed where a public water system may be contaminated with any substance that could cause a pollutional hazard.

(B) The type of protection required under paragraph (E) of rule [3745-95-04](#) of the Administrative Code shall be an approved air gap separation or an approved interchangeable connection. A removable spool piece connection is not an acceptable method.

(C) Where an auxiliary water system is used as a secondary source of water for a fire protection system, the provisions of paragraph (B) of this rule for an approved air gap separation or an approved interchangeable connection may be waived by the director, provided the following conditions exist:

(1) At premises where the auxiliary water system may be contaminated with substances that could cause a system, health or severe health hazard, a public water system or a consumer's water

system shall be protected against backflow by installation of an approved reduced pressure principle backflow prevention assembly or an approved reduced pressure principle-detector check assembly.

(2) At all other premises, a public water system or a consumer's water system shall be protected against backflow by installation of an approved reduced pressure principle backflow prevention assembly, an approved reduced pressure principle-detector check assembly, an approved double check valve assembly or an approved double check-detector check valve assembly.

(3) A public water system or a consumer's water system shall be the primary source of water for the fire protection system

(4) The fire protection system shall be normally filled with water from a public water system or a consumer's water system.

(5) The water in the fire protection system shall be used for fire protection only, with no other use of water from the fire protection system downstream from the approved backflow prevention device.

(D) An exception to the requirement in paragraph (A)(2) of this rule may be applied when mitigating the health hazard associated with a water-only, residential-type irrigation system that is not subjected to backpressure and is not equipped with pumps or other prime movers which can create backpressure to the public or the consumer's water system. In this instance, an approved pressure vacuum breaker can be used to isolate the service line to the irrigation system in lieu of installing a containment assembly at the service connection. The same maintenance and testing requirements as outlined in rule for containment assemblies apply. This exception does not apply if an additive is used within the irrigation system. The supplier of water may determine other hazards exist that warrant additional containment protection at the service connection.

Effective: 10/26/2015

Five Year Review (FYR) Dates: 07/06/2015 and 10/26/2020

Promulgated Under: [119.03](#)

Statutory Authority: [6109.04](#)

Rule Amplifies: [6109.04](#), [6109.13](#)

Prior Effective Dates: 07/01/72, 11/26/80, 05/01/03

3745-95-06 BACKFLOW PREVENTION DEVICES.

(A) Any containment principle backflow preventer required by rules [3745-95-04](#) and [3745-95-05](#) of the Administrative Code shall be of a model or construction approved by the supplier of water and conform to at least one of the following standards:

(1) For air gap separations: the specific edition of the American national standards institute (ANSI) and the American society of mechanical engineers (ASME) standard as referenced in rule [4101:3-13-01](#) of the Administrative Code.

(2) For reduced pressure principle backflow prevention assemblies: the specific edition of the ANSI and the American water works association (AWWA) standard, or the American society of sanitary engineering (ASSE) standard, or the Canadian standards association (CSA) standard as referenced in rule [4101:3-13-0](#) of the Administrative Code; or the foundation for cross-connection control and hydraulic research, university of Southern California specifications of backflow assemblies for reduced pressure principle assemblies - tenth edition (2009)

(3) For double check valve assemblies: the specific edition of the ANSI and the AWWA standard, or the ASSE standard, or the CSA standard as referenced in rule [4101:3-13-0](#) of the Administrative Code; or the foundation for cross-connection control and hydraulic research, university of Southern California specifications of backflow assemblies for double check valve assemblies - tenth edition (2009).

(4) For reduced pressure principle-detector assemblies: the specific edition of the ANSI and the ASSE standard, or the CSA standard as referenced in rule [4101:3-13-01](#) of the Administrative Code, or the foundation for cross-connection control and hydraulic research, university of Southern California specifications of backflow assemblies for reduced pressure principle-detector assemblies - tenth edition (2009).

(5) For double check-detector check valve assemblies: the ANSI and the ASSE standard, or the CSA standard as referenced in rule [4101:3-13-01](#) of the Administrative Code, or the foundation for cross-connection control and hydraulic research, university of Southern California specifications of backflow assemblies

for double check-detector assemblies - tenth edition (2009).

(6) For pressure vacuum breakers: the ANSI and the ASSE standard, or the CSA standard as referenced in rule [4101:3-13-01](#) of the Administrative Code.

(B) Any containment principle backflow preventer required by rules [3745-95-04](#) and [3745-95-05](#) of the Administrative Code shall be installed at a location and in a manner approved by the supplier of water and shall be installed at the expense of the water consumer. In addition, any backflow prevention device required by paragraphs (B) and (C) of rule [3745-95-05](#) of the Administrative Code shall be installed at a location and in a manner approved by the director as required by section [6109.13](#) of the Revised Code.

(C) It shall be the duty of the water consumer to maintain any containment principle backflow preventer required by rules [3745-95-04](#) and [3745-95-05](#) of the Administrative Code in proper working order and in continuous operation.

(1) The supplier of water shall retain authority over any containment principle backflow preventer required by rules [3745-95-04](#) and [3745-95-05](#) of the Administrative Code.

(2) It shall be the duty of the supplier of water to see that the tests and inspections required under this paragraph are made.

(3) The consumer shall, on any premises on which any containment principle backflow preventer required by rules [3745-95-04](#) and [3745-95-05](#) of the Administrative Code are installed, have thorough inspections and operational tests made of the backflow preventers at the time of installation or repair, and as may be reasonably required by the supplier of water or the director, but in all cases at least once every twelve months. These inspections and tests shall be at the expense of the water consumer and shall be performed by the supplier of water or a person approved by the supplier as qualified to inspect and test backflow preventers.

(4) These devices shall be repaired, overhauled or replaced at the expense of the consumer whenever they are found to be defective.

(5) Records of such inspections, tests, repairs and overhaul shall be kept by the consumer and made available to the supplier of water.

(6) The supplier of water shall maintain a paper or electronic record of inventory of survey, investigation and containment principle backflow preventer installation reports. Records of inspections, tests, repairs and overhauls related to the containment principle backflow preventer required by rules [3745-95-04](#) and [3745-95-05](#) of the Administrative Code shall be maintained by the supplier of water for a minimum of five years.

(D) The supplier of water shall inspect or cause to be inspected all installations where an approved connection exists between an auxiliary water system and the public water system or a consumer's water system at least once every twelve months and shall maintain an inventory of all such installations and inspection records. Such inventories and inspection records shall be made available during sanitary surveys and at other reasonable times. Paper or electronic inspection records shall be maintained by the supplier of water for a minimum of five years.

(E) Containment principle backflow preventers approved by the supplier of water and conforming to prior or subsequent editions of the standards cited in paragraph (A) of this rule, and which are properly maintained in accordance with paragraph (C) of this rule shall be excluded from the requirements of paragraphs (A) and (B) of this rule if the supplier of water and the director are assured that the backflow preventer will satisfactorily protect the public water system.

[Comment: This rule incorporates portions of the following manual by reference: The Manual of Cross-connection Control, Tenth Edition, published by the Foundation for Cross-connection Control and Hydraulic Research, University of Southern California. At the effective date of this rule, a copy of this document may be obtained from the Foundation for Cross-connection Control and Hydraulic Research, University of Southern California, Research Annex 219, 3716 Hope Street, Los Angeles, CA 90089-7700, phone: 866-545-6340, world-wide web address: <http://www.usc.edu/dept/fccchr/>. This document is available for review at Ohio EPA, Lazarus Government Center, 50 West Town Street, Suite 700, Columbus, OH 43215.]

Replaces: 3745-95-06

Effective: 10/26/2015

Five Year Review (FYR) Dates: 10/26/2020

Promulgated Under: [119.03](#)

Statutory Authority: [6109.04](#)

Rule Amplifies: [6109.04](#), [6109.13](#)

Prior Effective Dates: 07/01/72, 11/26/80, 05/01/03

3745-95-07 BOOSTER PUMPS.

(A) No person shall install or maintain a water service connection where a booster pump has been installed, unless an approved method is in place and is operational to maintain a minimum suction pressure as prescribed in the following:

(1) For booster pumps not intended to be used for fire suppression, no person shall install or maintain a water service connection to any premises where a booster pump has been installed on the service line to or within such premises, unless such booster pump is equipped with a low pressure cut-off designed to shut-off the booster pump when the pressure in the service line on the suction side of the pump drops to ten pounds per square inch gauge or less.

(2) For booster pumps used for fire suppression, also referred to as fire pumps, no person shall install or maintain a water service connection to any premises where a fire pump has been installed on the service line to or within such premises, unless the pump is equipped with one of the following:

(a) A low suction throttling valve which is a pilot-operated valve installed in the discharge piping that maintains positive pressure in the suction piping, while monitoring pressure in the suction piping through a sensing line. The valve must throttle the discharge of the pump when necessary so that suction pressure will not be reduced below ten pounds per square inch gauge while the pump is operating.

(b) A variable speed suction limiting control which is a speed control system used to maintain a minimum positive suction pressure at the pump inlet by reducing the pump driver speed while monitoring pressure in the suction piping through a sensing line. It will be set so that the suction pressure will not be reduced below ten pounds per square inch gauge while the pump is operating.

(3) Booster pumps used for fire suppression, also referred to as fire pumps, installed prior to

August 8, 2008, which are equipped with a low pressure cut-off as defined in paragraph (A) (1) of this rule, are not required to be modified solely for the purpose of meeting the new methods accepted after this date, under paragraph (A)(2) of this rule.

(B) The water consumer shall maintain the low pressure cut-off device, the low suction throttling valve, or the variable speed suction limiting control in proper working order and certify to the supplier of water, at least once every twelve months that the minimum suction pressure sustaining method is operable and maintained in continuous operation.

(C) The supplier of water shall maintain electronic or paper records of inventory of booster pump installations. Electronic or paper records certifying operation must be retained for a period of five years.

(D) The provisions of this rule shall be followed notwithstanding inconsistent provisions in the Great Lakes-Upper Mississippi River Board of State and Provincial Public Health and Environmental Managers' or "Recommended Standards for Water Works" (2012).

[Comment: "Recommended Standards for Water Works" 2012 edition. Copies are available from "Ohio EPA, Lazarus Government Center, 50 West Town Street, Suite 700, Columbus, OH 43215, (614) 644-2752" or online at <http://10statesstandards.com> or www.epa.ohio.gov/ddagw.]

Replaces: 3745-95-07

Effective: 10/26/2015

Five Year Review (FYR) Dates: 10/26/2020

Promulgated Under: [119.03](#)

Statutory Authority: [6109.04](#)

Rule Amplifies: [6109.04](#), [6109.13](#)

Prior Effective Dates: 07/01/72, 11/26/80, 05/01/03, 08/08/08

3745-95-08 VIOLATIONS.

(A) After reasonable notice to the occupants thereof supplier of water shall deny or discontinue, the water service to any premises wherein any of the following occurs;

(1) A backflow required by this chapter is not installed, tested and maintained in a

manner acceptable to the supplier of water.,

(2) The backflow preventer has been removed or by-passed.

(3) An unprotected cross-connection exists on the premises.

(4) A low pressure cut-off, low suction throttling valve or variable speed suction limiting control, as required by rule [3745-95-07](#) of the Administrative Code. Is not installed or maintained in working order.

(5) The supplier of water or the director, or the authorized representative or either, is denied entry to determine compliance with this chapter.

(B) Water service to such premises shall not be restored until the consumer has corrected or eliminated such conditions or defects in conformance with this chapter, and to the satisfaction of the supplier of water.

R.C. [119.032](#) review dates. 01/07/2013 and 01/07/2018

Promulgated Under: [119.03](#)

Statutory Authority: [6109.04](#)

Rule Amplifies: [6109.03](#), [6109.04](#), [6109.13](#)

Prior Effective Dates: 7/1/72

3745-95-09 REQUIREMENTS FOR YARD HYDRANTS.

(A) Yard hydrants with weep holes.

(1) Yard hydrants with weep holes used for human consumption installed on a public water system are prohibited unless the weep holes are sealed.

(2) Yard hydrants with weep holes not used for human consumption installed on a public water system, and those installed on a consumer's water system, shall have an appropriate backflow prevention assembly on the service line to protect the public water system. Yard hydrants with weep holes installed on public water systems shall be clearly labeled as "non-potable" or "not for human consumption."

(B) Sanitary yard hydrants that do not have weep holes, such as those that meet the requirements of the "American Society of Sanitary Engineers (ASSE) standard 1057, Performance Requirements for Freeze Resistant Yard Hydrants with Backflow Protection" (2001), are not prohibited provided:

(1) The device is acceptable to the public water system to which it will be connected; and

(2) Any other applicable backflow prevention and cross-connection control requirements of this chapter are met.

Effective: 04/19/2012

R.C. [119.032](#) review dates: 09/28/2011 and 03/09/2017

Promulgated Under: [119.03](#)

Statutory Authority: [6109.04](#)

Rule Amplifies: [6109.03](#), [6109.04](#), [6109.13](#)

Prior Effective Dates: 02/15/51, 11/26/80, 10/01/06

SECTION XIV. BACKFLOW PREVENTION DEVICES

APPROVED AIR-GAP SEPARATION — ANSI 112.1

An approved air-gap separation creates a physical separation between the water user's piping system and the reservoir being supplied. This is the most positive mechanical means of preventing backflow as long as the air-gap has been properly installed, inspected and maintained.

REQUIREMENTS

- Is measured from the supply line outlet opening to the flood level rim of the reservoir being supplied.
- Must be at least twice the diameter of the effective opening of the supply line outlet, or a distance of one inch, whichever is greater.
- Must be inspected at the time of installation and at least every 12 months thereafter.

ADVANTAGES

Is approved protection against a severe health hazard.

LIMITATIONS

Can be easily bypassed by connecting a hose to the discharge end of the supply line.

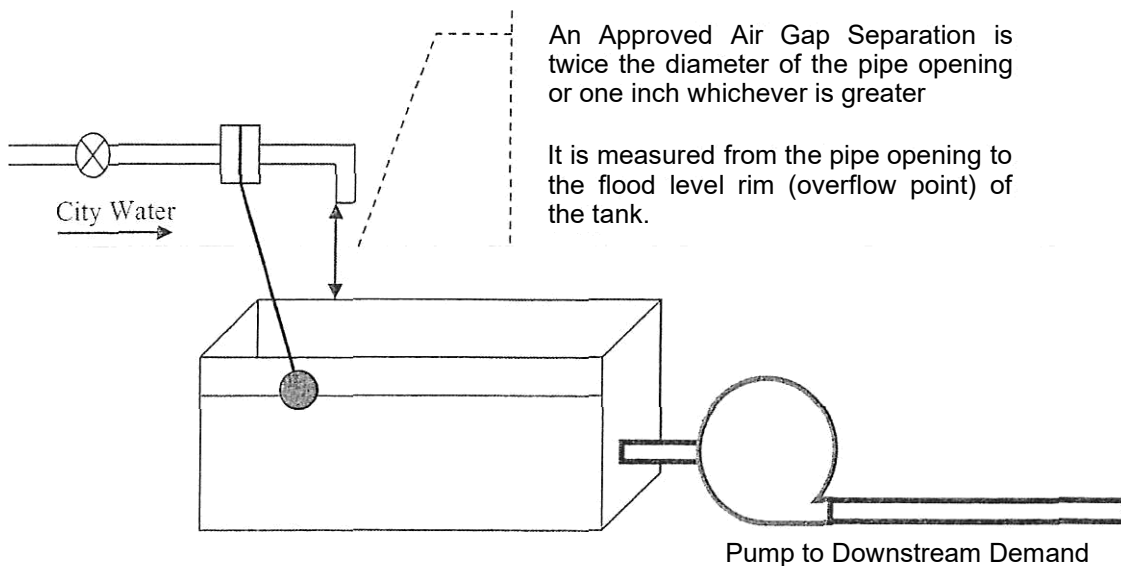

REDUCED PRESSURE ASSEMBLY — ASSE 1013

LIMITATIONS

- IS not normally approved protection against a severe health hazard.
- There may be a significant pressure loss through the device under maximum flow conditions.
- There may be sporadic water discharges from the relief valve port.
- May not be installed in a pit.

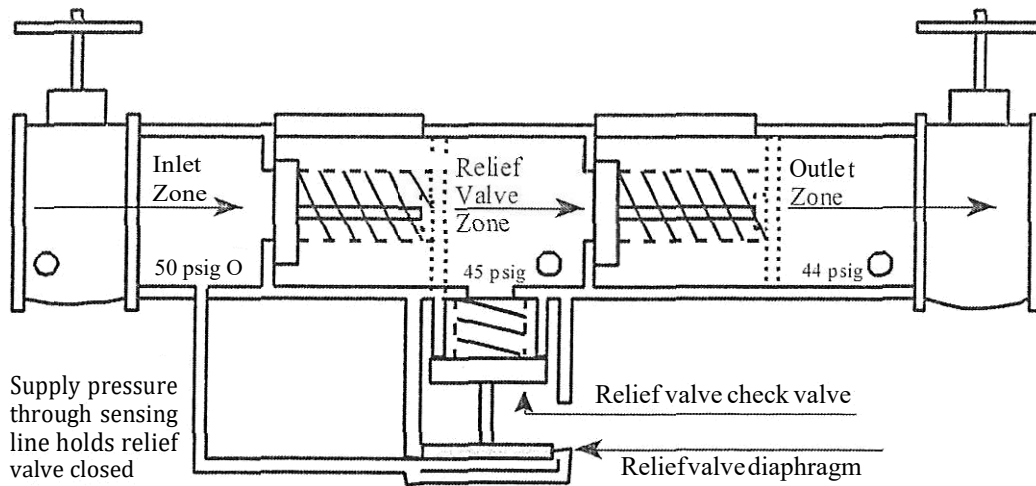

O = test cocks

TEST POINT	MINIMUM TEST REQUIREMENT
Check Valve Number 1	The minimum acceptable pressure loss is 5 psid, but to pass the test it must create a loss equal to or greater than the relief valve opening; point plus 3 psi
Differential Pressure Relief Valve	The relief valve must vent water before the pressure in the relief valve zone comes within a minimum 2 psid of the supply pressure
Check Valve Number 2	Must hold tightly against backpressure
Shut-off Valve # 2	Must be drip-tight

DOUBLE CHECK VALVE ASSEMBLY — ASSE 1015

ADVANTAGES

- Is approved as protection against a pollution or low hazard.
- May be used under continuous pressure.
- Provides protection against backpressure and backsiphonage.
- There is a minimal head loss under flow conditions.

LIMITATIONS

- Gives no visible indication of a check valve failure.
- Is not approved for use as protection against a system, health or severe health hazard.

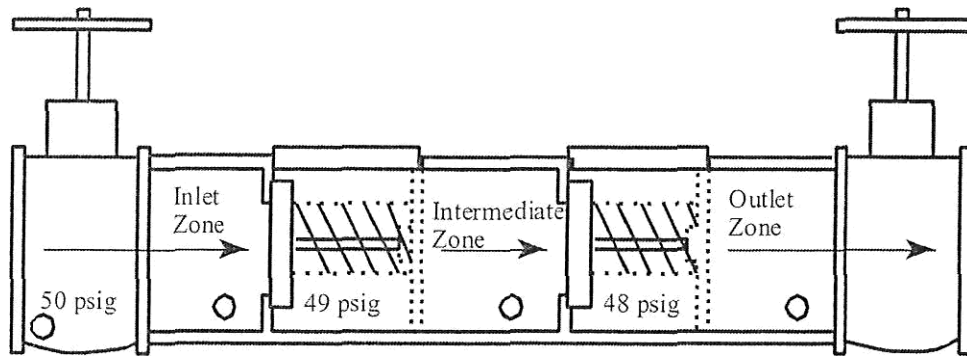

O = test cocks

TEST POINT	MINIMUM TEST REQUIREMENT
Shut-off Valve #2	Must be drip-tight
Check Valve Number 1	Must create a minimum 1 psid of pressure loss
Check Valve Number 2	Must create a minimum 1 psid of pressure loss

PRESSURE VACUUM BREAKER — ASSE 1020

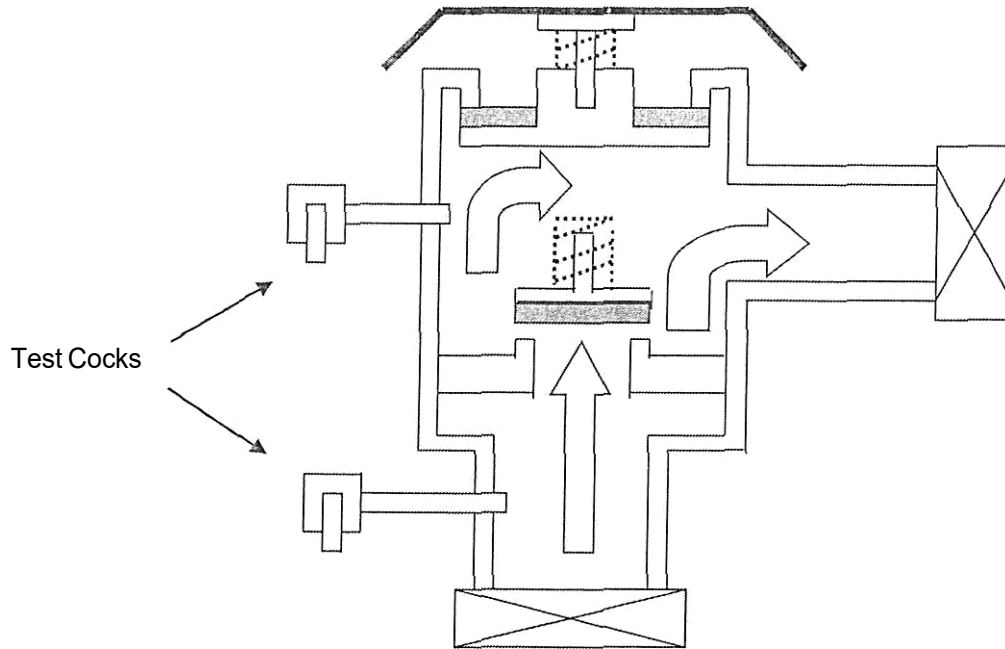

Flow Conditions

1. There is flow downstream
2. The spring-loaded check valve is held open by the water pressure
3. The spring-loaded air-inlet valve is held closed by the water pressure

TEST POINT	MINIMUM TEST REQUIREMENT
Air-Inlet Valve	The minimum opening point must be 1 psig
Check Valve	Must create a minimum 1 psig pressure loss

SESSION 4 — BACKFLOW PREVENTION ASSEMBLIES & DEVICES

REDUCED PRESSURE DETECTOR CHECK ASSEMBLY—ASSE 1047

A reduced pressure detector check assembly is a specially designed assembly composed of a line-sized approved reduced pressure principle backflow prevention assembly with a smaller bypass water meter and a meter-sized reduced pressure principle backflow prevention assembly. The meter shall register accurately for only very low rates of flow and shall show a registration for all rates of flow.

- This assembly would be used on a dedicated fire protection system that is a direct connection from the public water system and that contains any additives, or utilizes a non-potable storage tank or reservoir, or could be inter-connected with an auxiliary water source.
- Many water utilities are beginning to require these assemblies on all new fire protection service connections.
- It is called a detector assembly because the water meter on the bypass would detect fire flow, system leakage, or unauthorized use.
- The full line-sized reduced pressure assembly and the bypass reduced pressure assembly must be tested at the time of installation and every twelve months thereafter.
- Care must be taken before retrofitting an existing fire protection system, a fire protection contractor should be consulted to determine if a larger service connection should be installed due to the additional head loss

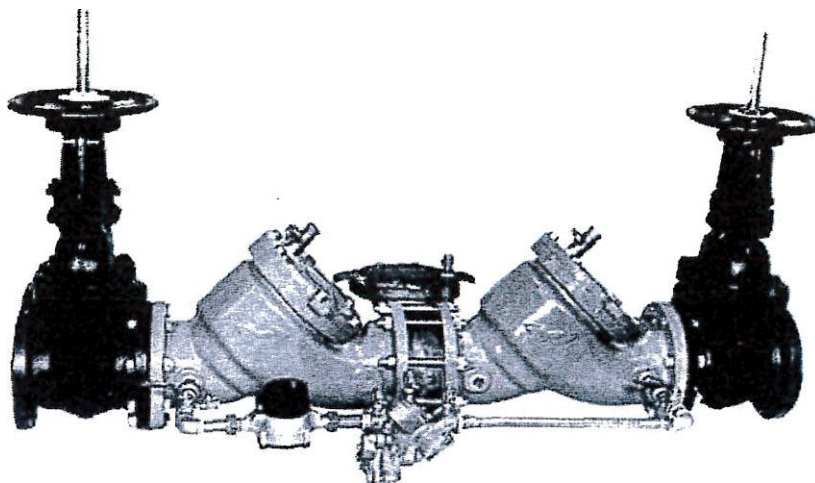

FIGURE 6

SESSION 4 — BACKFLOW PREVENTION ASSEMBLIES & DEVICES

DOUBLE CHECK DETECTOR CHECK ASSEMBLY — ASSE 1048

A double check detector check assembly is a specially designed assembly composed of a line-sized approved double check valve assembly with a smaller bypass water meter and a meter-sized double check valve assembly. The meter shall register accurately for only very low rates of flow and shall show a registration for all rates of flow.

- This assembly would be used on a dedicated fire protection system that is a direct connection from the public water system, has no chemical additives, or that includes a properly constructed water storage tank containing potable water.
- Many water utilities are beginning to require these assemblies on all new fire protection service connections.
- It is called a detector assembly because the water meter on the bypass would detect fire flow, system leakage, or unauthorized use
- The full line-sized double check assembly and the bypass double check assembly must be tested at the time of installation and every twelve months thereafter
- Care must be taken before retrofitting an existing fire protection system, a fire protection contractor should be consulted to determine if a larger service connection should be installed due to the additional head loss

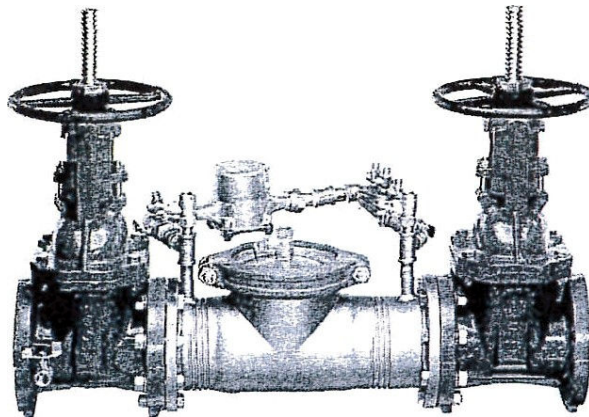

BACKFLOW PREVENTION APPLICATION CHART

DEVICE	ASSE NO.	HAZARD LEVEL	PROTECTION PROVIDED
Air Gap Separation	ANSI A112. 1	Severe High, High or Low Hazard	Backsiphonage / Backpressure
Pipe Applied Atmospheric Vacuum Breaker	ASSE 1001	High or Low Hazard	Backsiphonage Only No continuous pressure
Water Closet Ballcock Anti-Siphon Type	ASSE 1002	High or Low Hazard	Backsiphonage Only
Hose Connection Vacuum Breaker	ASSE 1011	High or Low Hazard	Backsiphonage Only No continuous pressure
Backflow Preventer with Intermediate Atmospheric Vent	ASSE 1012	Low Hazard Only Low Pressure	Backsiphonage / Backpressure
Reduced Pressure Principle Backflow Preventer	ASSE 1013	High or Low Hazard	Backsiphonage / Backpressure
Reduced Pressure Principle Detector Check Assembly	ASSE 1047	High or Low Hazard fire sprinkler systems	Backsiphonage / Backpressure
Double Check Valve Assembly	ASSE 1015	Low Hazard Only	Backsiphonage / Backpressure
Double Check Detector Check Assembly	ASSE 1048 1-1/2" - 10"	Low Hazard Only fire sprinkler systems	Backsiphonage / Backpressure
Frost Proof Wall Hydrant, Automatic Draining	ASSE 1019	High or Low Hazard	Backsiphonage Only No continuous pressure
Pressure Vacuum Breaker	ASSE 1020	High or Low Hazard	Backsiphonage Only
Backflow Preventer for Carbonated Beverage Dispenser	ASSE 1022	High or Low Hazard	Backsiphonage / Backpressure
Dual Check Valve Type Backflow Preventer	ASSE 1024	Low Hazard Only	Backsiphonage / Backpressure
Dual Check Valve Type Backflow Preventer for Post-Mix Beverage Dispenser	ASSE 1032	Low Hazard Only	Backsiphonage / Backpressure
Laboratory Faucet Vacuum Breaker	ASSE 1035	High or Low Hazard	Backsiphonage Only No continuous pressure
Hose Connection Vacuum Breaker	ASSE 1052	High or Low Hazard	Backsiphonage Only
Backsiphonage Vacuum Breaker, Spill-Proof	ASSE 1056	High or Low Hazard	Backsiphonage Only

DEVICE SELECTION CHART

TYPE OF CROSS-CONNECTION	HAZARD LEVEL	M-Minimum				O-Optimal	
		AG ANSI A112.1	RPZ ASSE 1013	DCV ASSE 1015	PVB ASSE 1020	RPDCA ASSE 1047	DCDGA ASSE 1048
Connection to pressurized system that contains	Severe High Hazard	M					
	High Hazard		M				
	Low Hazard		O	M			
Make-up lines to chilled hydronics systems that contain	Severe High Hazard	M					
	High Hazard		M				
	Low Hazard		O	M			
Fire protection systems that contain	Severe High Hazard	M					
	High Hazard					M	
	Low Hazard					O	M
Lawn sprinkler and irrigation systems with	Pumped injection		M				
	No injection		O	O	M		

AG — Air Gap

RPZ - Reduced Pressure Zone Backflow Preventer

DCV - Double Check Valve Backflow Preventer

PVB — Pressure Vacuum Breaker

RPDCA - Reduced Pressure Detector Check Assembly

DCDA — Double Check Detector Check Assembly

DEGREE OF HAZARD EVALUATION TERMS

Ohio Department of Commerce

Severe High Hazard

High Hazard

High Hazard

Low Hazard

Ohio Environmental Protection Agency

Severe Health Hazard

Health Hazard

System Hazard

Pollution Hazard

The following types of facilities will require the designated backflow prevention devices. The list is presented as a guideline and should not be construed as being final or complete. Each case will be judged by its own merit.

Abbreviations Used are as follows:

RP	Reduced Pressure Type Backflow Device
DC	Double Check Valve Backflow Preventer
DCDC	Double Check Detector Check Assembly
RPDC	Reduced Pressure Detector Check Assembly
CCI	Cross Connection Control Inspection

TYPE OF FACILITY

Auxiliary Water Supply
(any supply other than ours)

Car Wash

Chemical Plant

Convenience Stores

Film Laboratory or Development

Fire Protection System:

(without auxiliary water or process water)

(with auxiliary water or process water)

TYPE OF PROTECTION

CCI and RP

RP

RP

DC

RP

DCDC

RPDC

Food or Beverage Processing Plants	DC
Funeral Homes - Mortuaries	RP
General Office Buildings	DC
Laundries - Dry Cleaners	DC or RP
Machine Tool Plants (degree of hazard)	DC or RP
Medical Facilities:	
Hospitals	RP
Clinics	RP
Veterinary	RP
Offices	RP
Metal Processing/Production (degree or hazard)	DC or RP
Multi-residential Facilities	DC
Paper Products	RP
Petroleum Processing Plant	RP
Petroleum Storage Plant/Yard	DC or RP
Plating Facilities	RP
Restaurants	DC
Schools (degree of hazard)	RP
Sprinkling and Irrigation Systems	DC
Strip Shopping Malls	DC
Sewage Treatment Plants	RP
Sewage Pumping Station (degree of hazard)	DC or RP
Irrigation Systems	RP (above grade in hot- box or in building)
Other	CCI and RP

REFERENCES

BACKFLOW PREVENTION AND CROSS CONNECTION CONTROL, MANUAL M-14, 1966;
AMERICAN WATER WORKS ASSOCIATION

CROSS CONNECTIONS & BACKFLOW PREVENTION, SECOND EDITION;
BY GUSTAVE J. ANGELS Sr., AMERICAN WATER WORKS ASSOCIATION

BACKFLOW PREVENTION AND CROSS-CONNECTION CONTROL, THIRD EDITION, 1987
STATE OF OHIO ENVIRONMENTAL PROTECTION AGENCY

OHIO ADMINISTRATIVE CODE, CHAPTER 3745-95
STATE OF OHIO

BACKFLOW-PREVENTION BY CONTAINMENT, 1988;
DEPARTMENT OF PUBLIC UTILITIES, GWINNETT COUNTY, GEORGIA

CHAPTER 4101:2-51 (OHIO PLUMBING CODE);
OHIO ADMINISTRATIVE CODE

MANUAL OF CROSS CONNECTION-CONTROL, EIGHTH EDITION
FOUNDATION FOR CROSS-CONNECTION CONTROL AND HYDRAULIC
RESEARCH UNIVERSITY OF SOUTHERN CALIFORNIA

GEAUGA COUNTY DEPARTMENT OF WATER RESOURCES
RULES AND REGULATIONS – 2015

Prepared by

Geauga County Department of Water Resources

2022

G:\Water\GCDWR\Bainbridge PWS\Backflow Prevention\GCDWR\GCDWR 2022 Policy And Procedures.docx